

LUBRICATION

AUTOMIZER RIGHT-HAND™ STANDARD BODY

LUBRICATION

AUTOMIZER RIGHT-HAND™

Table of Contents

2.0	LUBRICATION	2 - 5
2.1	RECOMMENDED LUBRICANTS	2 - 5
2.1.1	GREASE	2 - 5
2.1.2	HOPPER LUBRICATION	2 - 5
2.1.3	ENGINE OIL FOR VEHICLE	2 - 5
2.1.4	TRANSMISSION OIL FOR VEHICLE	2 - 5
2.1.5	HYDRAULIC OIL	2 - 5
2.1.6	HYDRAULIC OIL TEST	2 - 6
2.2	LUBRICATION CHART	2 - 10
2.3	AUTOMATED ARM	2 - 11
2.4	PACKER	2 - 13
2.5	BODY - CHASSIS HINGES	2 - 14
2.6	TAILGATE	2 - 15
2.7	HOPPER DOOR	2 - 16

2.0 LUBRICATION

2.1 RECOMMENDED LUBRICANTS

2.1.1 GREASE

Any lithium-base commercial multipurpose grease may be used. For Nordic regions, Shell Tellus T32 hydraulic oil is strongly recommended.

2.1.2 HOPPER LUBRICATION

SIDE RAILS AND THE EXTERIOR OF THE ROLLERS SHOULD **NOT** BE GREASED. Grease causes sand or other abrasives to stick to the grease and it results in premature wear of the components.

Refer to the following sections for detailed lubrication points on packer, cylinder pins, hopper door hinges and body-chassis hinges.

For vehicle equipped with special options such as comingle unit, refer to the section of the Parts and Service Manual related to those options.

2.1.3 ENGINE OIL FOR VEHICLE

Refer to the engine manufacturer's Maintenance Manual for recommended type of engine oil.

2.1.4 TRANSMISSION OIL FOR VEHICLE

Refer to the transmission manufacturer's Maintenance Manual for recommended type of transmission oil.

2.1.5 HYDRAULIC OIL

Minimum requirement for hydraulic oil:

Viscosity of 320 cSt at 104 °F (40 °C) and 6.4 cSt at 212 °F (100 °C).

The oil must contain anti-wear and anti-foam additives, rust and oxidation neutralizers and self-protecting agents.

The oil must also meet MIL-H-5606 or SAE IOW "MS" standards. The following oils may be used in the Automizer™.

Shell Tellus 32 or T-32



DANGER

DO NOT MIX DIFFERENT BRANDS OF OIL. IN DOUBT, DRAIN AND REFILL WITH NEW OIL.



CAUTION

BECAUSE OF ITS INTENSE USE, THE PACKER AND ITS ACCESSORIES MUST BE LUBRICATED EVERY WORKING DAY.

2.1.6 HYDRAULIC OIL TEST

It is recommended to have the hydraulic oil to be tested and analysed by a lab to prevent hydraulic system or pump breakdowns. This will also optimize the oil change frequency. Apply the following procedure to take oil samples on Labrie trucks. Note that the procedure may differ from other laboratories sample kit.

HYDRAULIC OIL TEST PROCEDURE

1. Apply all safety measures to ensure safety around the vehicle at all times.
2. Start the engine and raise the body.
3. Install the body safety prop and lower the body onto it.
4. Disengage the pump and turn off the engine.
5. Locate the oil sample coupler along the right- hand side chassis frame rail.

Hydraulic tank



The sample coupler is located at the back of the filter cover.



Hydraulic Tank

Sample coupler

HYDRAULIC OIL TEST PROCEDURE (Cont'd)

6. Remove the cap from the coupler and clean the sampler coupler using a clean rag.



7. Press on the coupler spring ball using a small tip to purge oil before taking sample. Use a small bucket to recuperate the oil that will come out. Let the oil leak for a few seconds (about half a cup). The residual pressure on the system will push the oil out of the coupler.



8. Remove the sample kit from its bag and using a screw driver, remove the vent cap from the bottle cap.

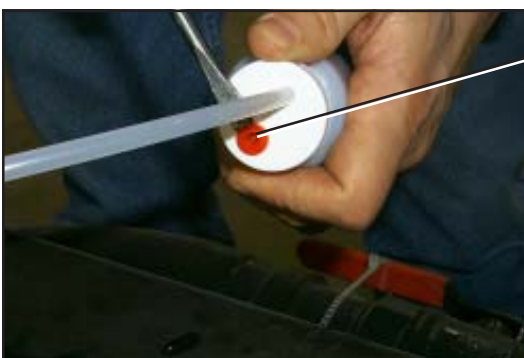

Vent
cap

HYDRAULIC OIL TEST PROCEDURE (Cont'd)

9. Remove the protective cap from the probe.

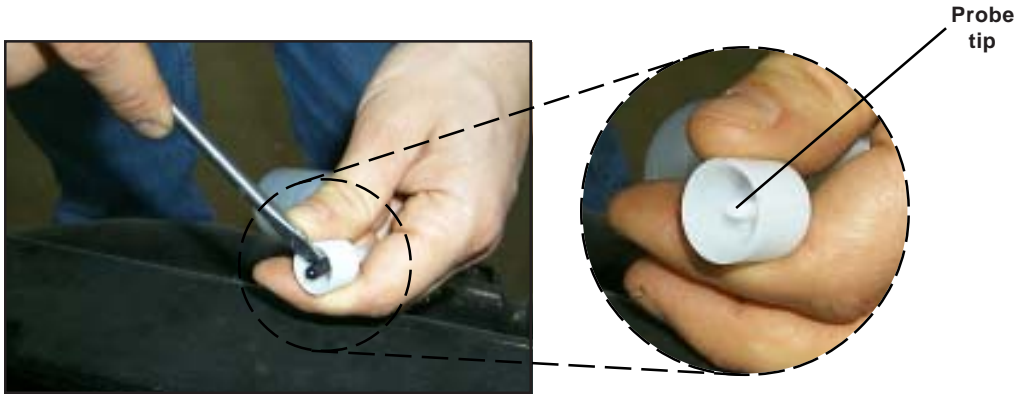

10. Install the probe on the coupler to fill the sample bottle. Use EMA coupler with M16 x 2.0 threads. Fill the bottle to the level mark. Remove any excess of oil through the vent. **DO NOT OPEN THE BOTTLE CAP.** If the oil flow is insufficient, or that no oil is coming out, engage the hydraulic pump. In that case, be careful of oil spills.

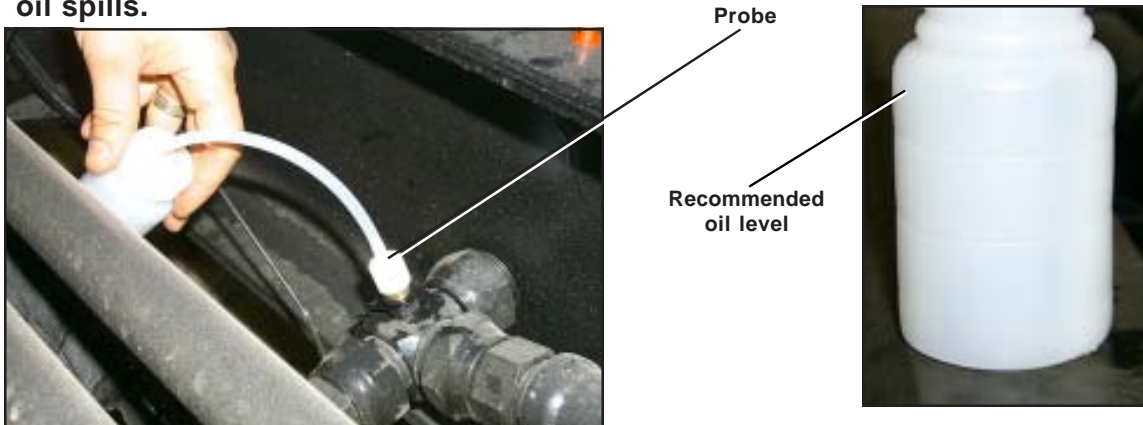

11. Once the sample is taken, remove the probe from the coupler and pull out the probe to remove it from the bottle.

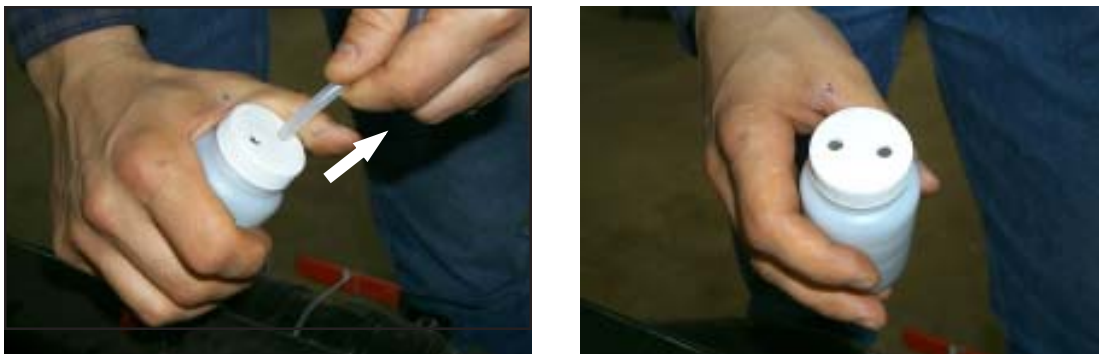

HYDRAULIC OIL TEST PROCEDURE (Cont'd)

12. Put the seal cover over the bottle cap.



13. Fill the identification form(sticker) and apply it on the sample bottle.

SAMPLE NO.	DATE	MACHINE/UNIT NO.	SYSTEM TYPE	CAPACITY GALS.
FLUID I.D.	FLUID MFGR.	SYSTEM CLI	RETURN RESULTS TO:	
LAST FILTER CHANGE DATE / /		LAST OIL CHANGE DATE / /		DEPT./NAME
ANALYSIS TYPE DESIRED		ADDRESS		
		CITY/STATE		
		ZIP		
		PHONE		





2.2 LUBRICATION CHART

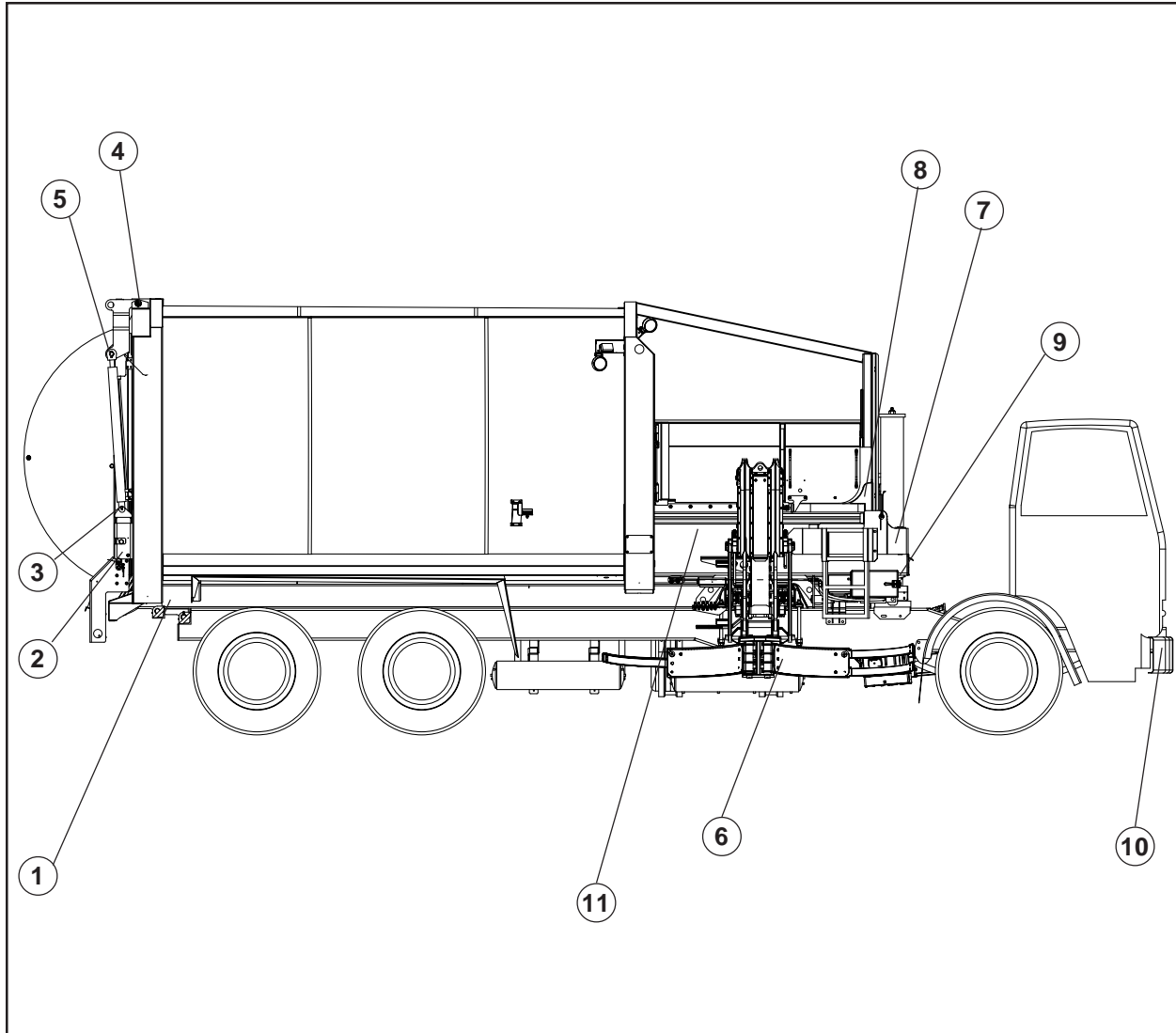

NO.	DESCRIPTION	FREQUENCY
1	BODY HINGES	WEEKLY
2	TAILGATE LOCKING MECHANISM	WEEKLY
3	TAILGATE CYLINDER LOWER AXIS	WEEKLY
4	TAILGATE HINGES	WEEKLY
5	TAILGATE CYLINDER UPPER AXIS	WEEKLY
6	AUTOMATED ARM PIVOTS	DAILY
7	BODY HOIST AXIS	WEEKLY
8	PACKER CYLINDER FRONT AXIS	TWICE A WEEK
9	BODY HOIST BASE AXIS	WEEKLY
10	PUMP DRIVE SHAFT	TWICE A WEEK
11	PACKER CYLINDER HOPPER AXIS	WEEKLY



2.3 AUTOMATED ARM



 Cylinder remote greasing system



 Grabber pivots (upper)



 Telescopic arm cylinders



 Grabber pivots (Lower)



2.3 AUTOMATED ARM



Lift Arm Cylinder



Telescopic arm bearings and rollers



Grabber cylinders



2.4 PACKER

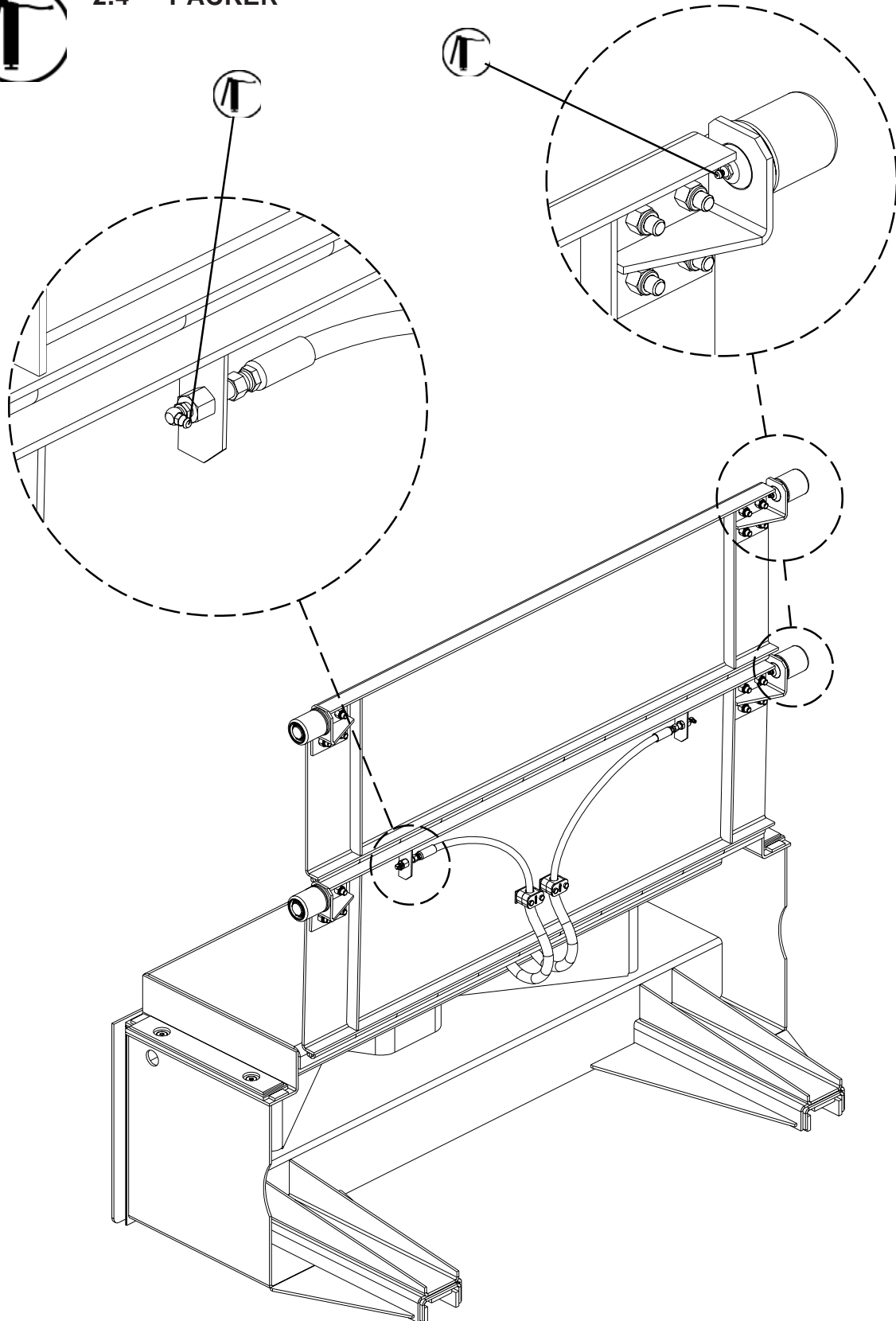



2.5 BODY - CHASSIS HINGES

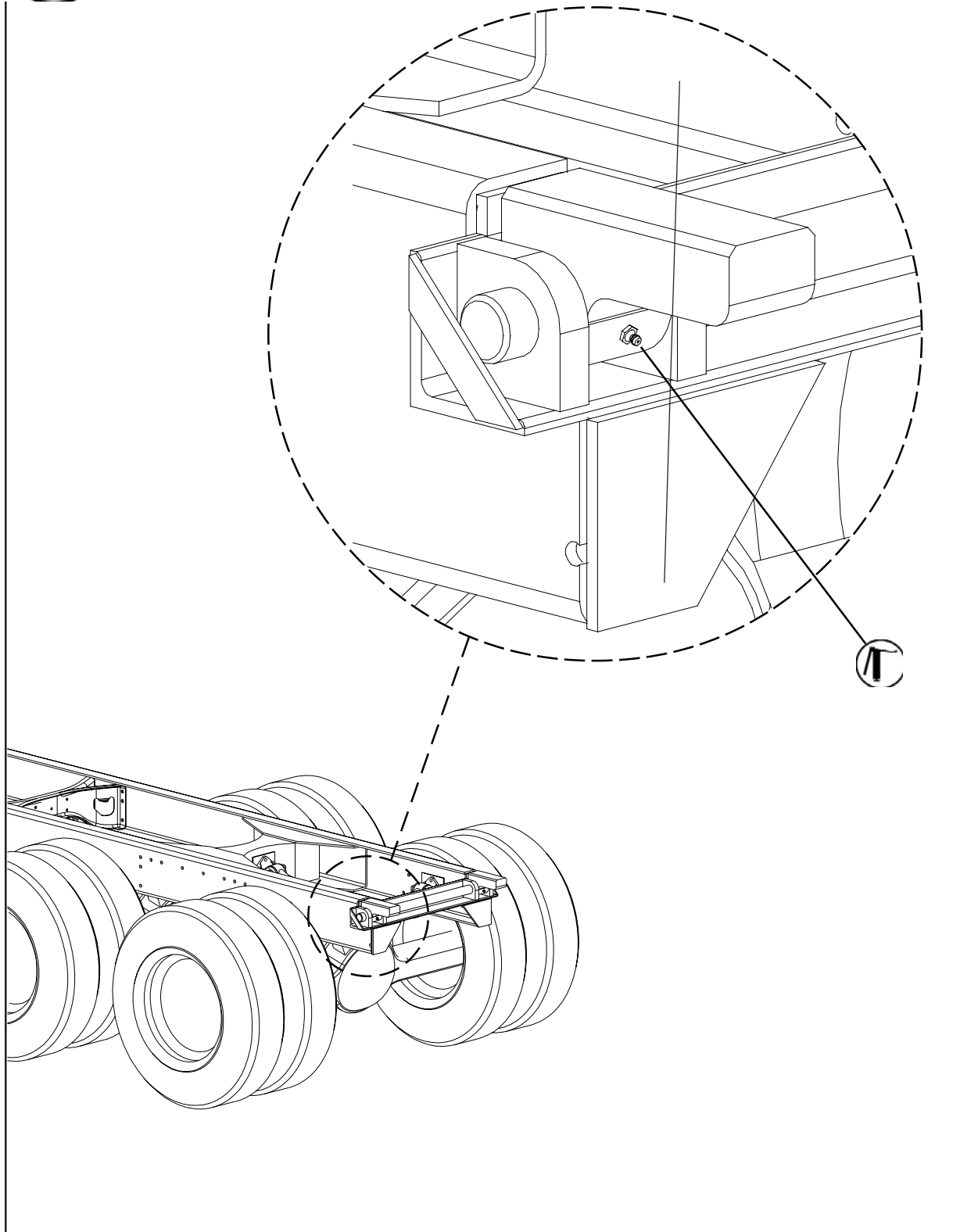



2.6 TAILGATE

Remote greasing system for tailgate hinges (optional)

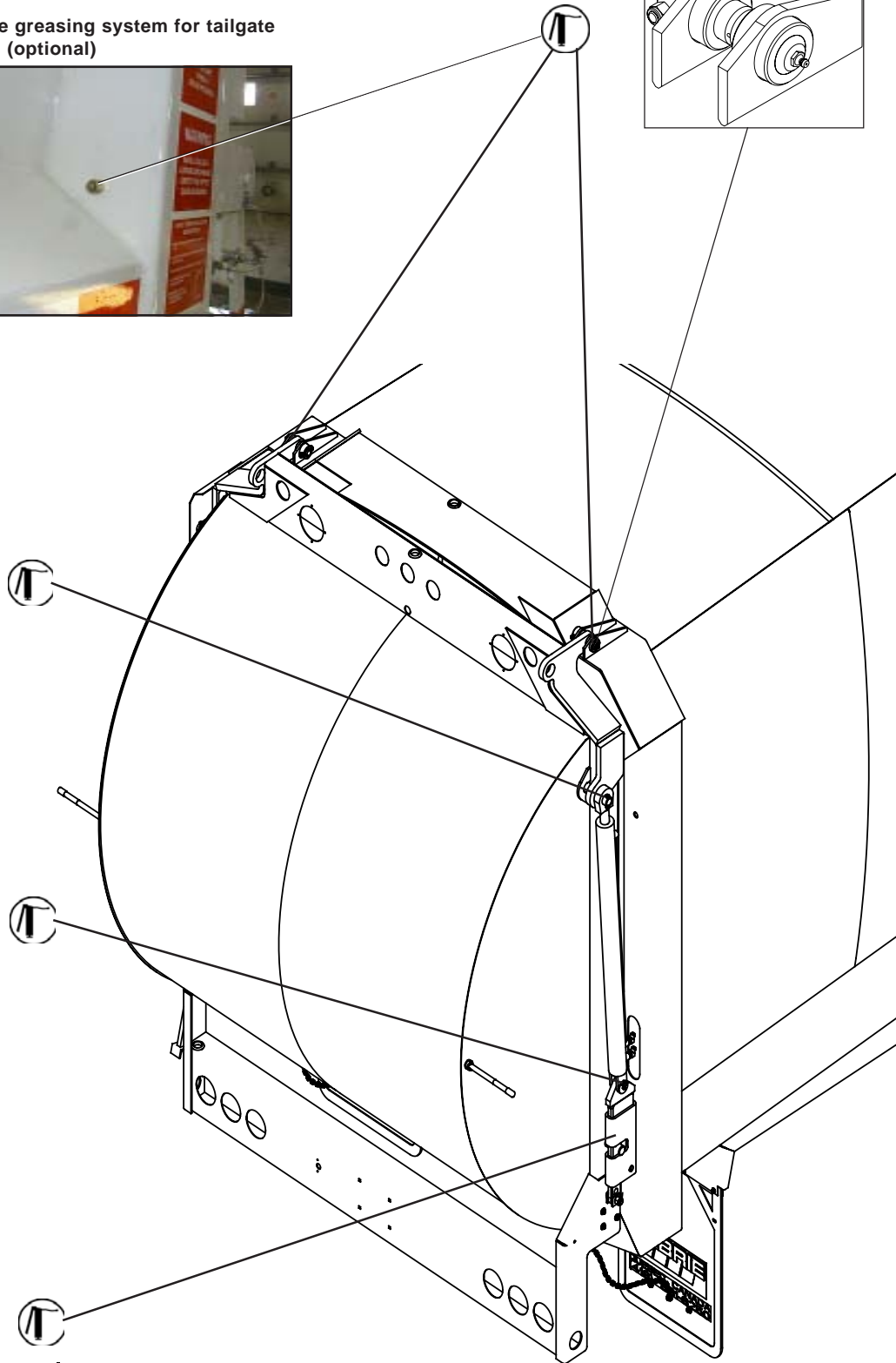
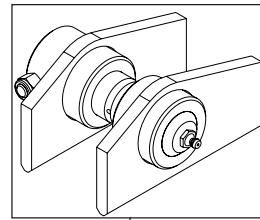



2.7 HOPPER DOOR

