



76 Series DiggerDrive™

3,300 TO 12,000 FT-LB TORQUE (TWO SPEED)

Data Sheet 7076

The series 76 is custom designed for the Utility Industry. This series is a two speed, double planetary drive with hydraulic or air operated mechanical shift. Eskridge has over 25 years of experience in the manufacture of DiggerDrives™ to dig holes and install anchors in the heavy duty electric utility environment.

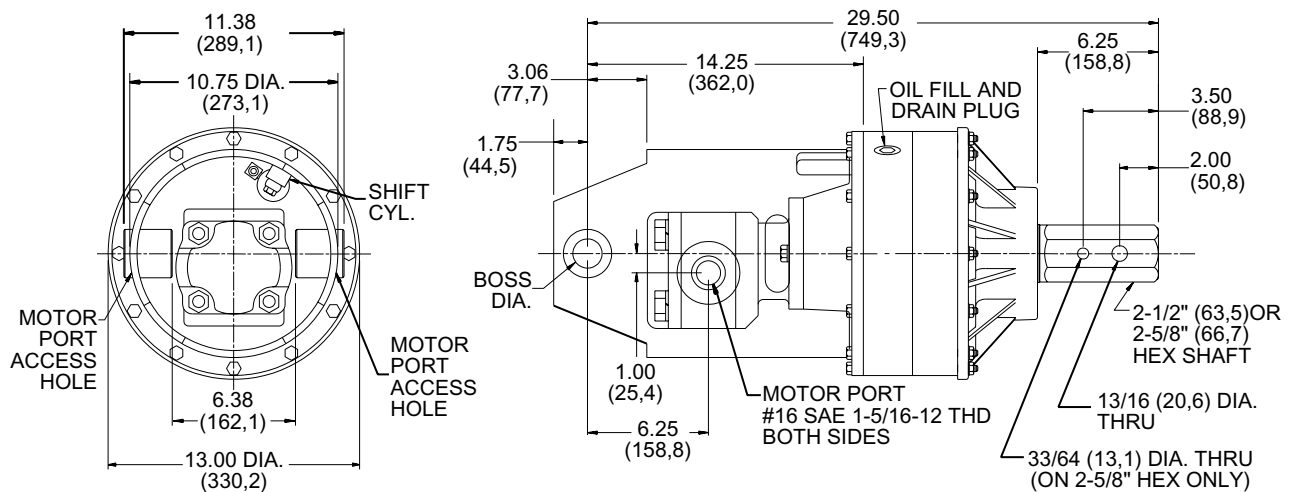

TWO-SPEED; HYDRAULIC AND AIR SHIFT OPTIONS
HEAVY DUTY, HIGH EFFICIENCY, DOUBLE PLANETARY DRIVE
HIGH SPEED SPIN-OFF

**THIS UNIT DOES NOT SHIFT ON THE FLY. IT MUST BE STOPPED
COMPLETELY BEFORE SHIFTING.
SHAFT SIDE LOADING NOT RECOMMENDED.**

TECHNICAL SPECIFICATIONS

MOTOR MOUNT: SAE "C" 2-BOLT
MOTORS: SINGLE SPEED GEAR TYPE
RATED OUTPUT TORQUES: TO 12,000 ft-lb (16,272 N-m)
MAXIMUM SYSTEM PRESSURE: 2,500 psi (172,4 bar)
MAXIMUM SHIFTING PRESSURE: 600 psi (41,4 bar (pressurize to shift to high)
OUTPUT SHAFT OPTIONS: 2-1/2" (63,5 mm) AND 2-5/8" (66,7 mm) HEX
SHAFT PULL-OUT LOAD: 15,000 lb (6818 kg)
SHAFT PRESSURE LOAD: 15,000 lb (6818 kg)
OIL CAPACITY: 6.5 pts (3,1 l)
BAIL BOSS DIAMETER: 1.26" (32,00 mm) OR 1.51" (38,35 mm)
WEIGHT: 250 lb (113,4 kg) WITH MOTOR

For more information regarding Planetary Diggerdrives and other innovative products, feel free to contact us at:



ESKRIDGE

1900 Kansas City Road • Olathe, Kansas 66061 • USA

PHONE: (913) 782-1238 • FAX: (913) 782-4206

WEBSITE: www.eskridgeinc.com • E-MAIL: sales@eskridgeinc.com

Performance Data

MODEL	GEAR RATIO		MOTOR	MOTOR PRESSURE Δpsi (Δbar)	FLOW gpm (l/min)	RATED TORQUE*		SPEED rpm	
	LOW	HIGH				LOW	HIGH	LOW	HIGH
	ft-lb. (N-m)								
76BA	70:1	17:1	03	2,400 (166)	40 (152)	12,000 (16,272)	3,000 (4,068)	19	80
76BC	46:1	19:1	03	2,400 (166)	40 (152)	8,000 (10,848)	3,300 (4,475)	30	72

* **Maximum intermittent value.**

APPROXIMATELY 25% LESS THAN RUNNING TORQUE.

- SYSTEM BACK PRESSURE WILL REDUCE THE RUNNING TORQUES PROPORTIONALLY.
- BACK PRESSURE SHOULD BE LIMITED TO 100 psi (6,9 bar).
- MAXIMUM FLOW RATE IS DEPENDENT UPON MOTOR DISPLACEMENTS.
- HIGH ALLOY HEAT TREATED BAIL BOSS PINS REQUIRED (CUSTOMER PROVIDED).

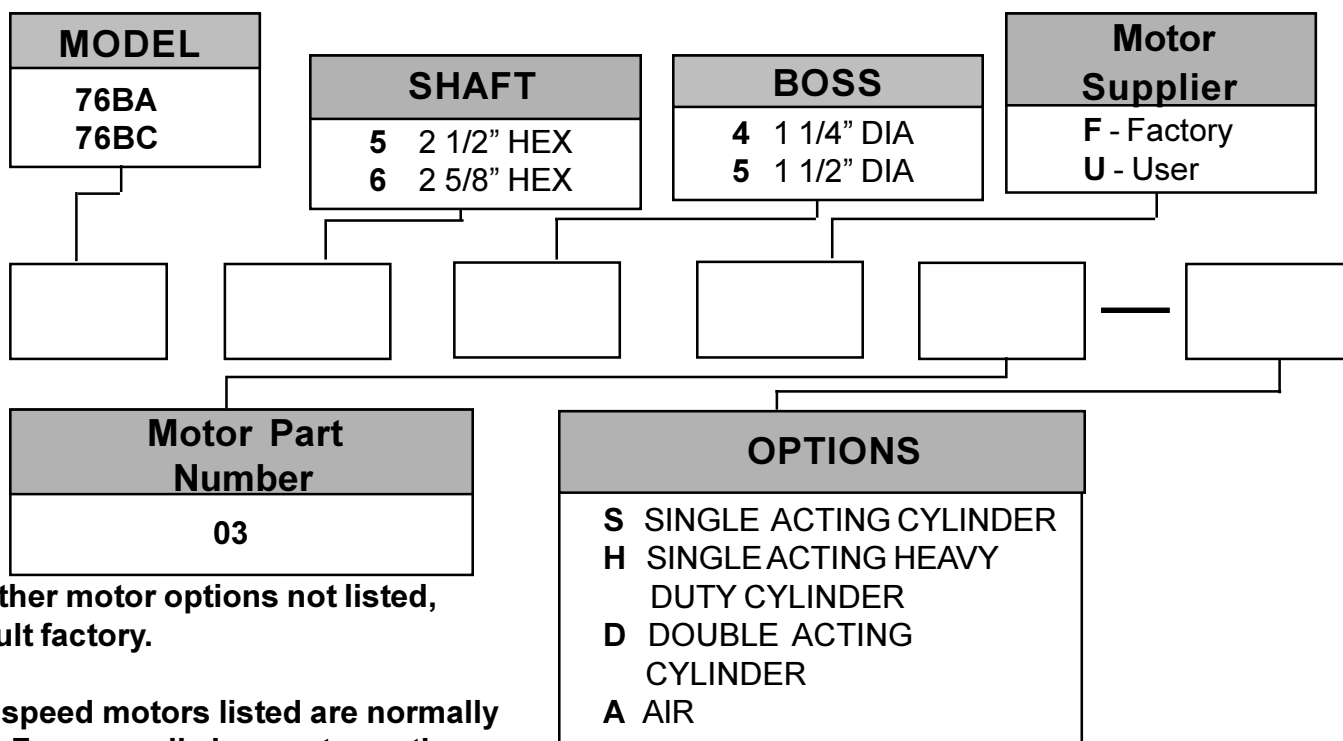

For other motor options not listed, consult factory.

*Two speed motors listed are normally high. For normally low motor option consult factory.

IMPORTANT INFORMATION...

ESKRIDGE, INC. EXPRESSLY DISCLAIMS ANY IMPLIED WARRANTY OF MERCHANTABILITY OR FITNESS FOR ANY PARTICULAR PURPOSE FOR THE PRODUCTS SHOWN HEREIN.

Any claims based on or related to the products shown herein will be satisfied only by repair or replacement in Eskridge, Inc.'s sole discretion to the extent covered by Eskridge's Product Warranty. Eskridge, Inc. is not liable for incidental or consequential damage of any kind or nature that relate in any way to the products shown herein. For complete warranty information, please refer to Eskridge, Inc.'s Product Warranty that applies to the products shown herein and is incorporated by this reference as if fully set forth. A copy of Eskridge, Inc.'s Product Warranty can be obtained by writing Eskridge, Inc. at P.O. Box 875, 1900 Kansas City Road, Olathe, Kansas 66061