

cobra 6206H

**PTO - HYDRAULIC CRANES
37,000 FT. LBS.**

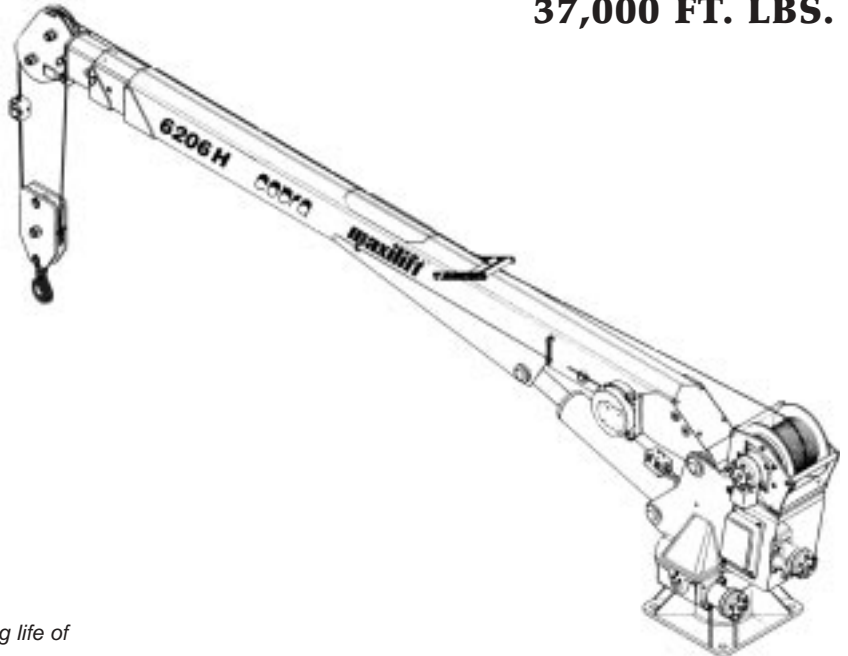

STANDARD FEATURES

- Engineered for 12 - 15 years of service*
- High strength hexagonal Swedish steel boom
- Fully hydraulic boom extension/retraction
- Twin worm gear rotation system
- Planetary rotation drive
- Load limiting device
- Proportional control valve
- Remote control - wireless and/or wired
- Emergency manual controls
- 2 part block
- Anti-2 block safety switch
- Painted Cobra white with polyurethane enamel

* Cobra crane structures are designed for a normal working life of 12 to 15 years according to the DIN Standard 15018 classification H2-B3.

TECHNICAL DATA

- Crane rating 37,000 ft. lbs.
- Horizontal reach 21 ft.
- Elevation angle -10 to +75 degrees
- Slewing angle continuous unlimited
- Winch capacity, bare drum 3,100 lbs.
- Winch speed, single line 46 fpm
- Wire rope, non-rotating 100 ft of 3/8"
- Oil flow and pressure 4.2 gpm@2,600 psi
- Crane weight 1,280 lbs.

LIFTING CAPACITIES

FT.	LBS.	FT.	LBS.
5	6200	14	2625
6	6200	15	2450
7	5275	16	2300
8	4625	17	2150
9	4000	18	2050
10	3700	19	1925
11	3350	20	1850
12	3075	21	1660
13	2825		

OPTIONS / ACCESSORIES

- Outriggers - manual or hydraulic
- Oil reservoir

