



## STANDARD FEATURES

- Engineered for 12 - 15 years of service\*
- High strength hexagonal Swedish steel boom
- Boom Extension 1 Hydraulic / 1 Manual
- Worm gear rotation system
- Hydraulic Planetary winch
- Load limiting device
- Single or Dual Proportional Control Valve
- Remote control - wireless and/or wired
- Emergency manual controls
- 2 part block
- Painted Cobra white with polyurethane enamel
- Cobra Diagnostics - displays safety, diagnostics and error codes
- 6 Standard Operator Safety and Crane Protection Devices
  - Overload Protection on all Functions
  - Counter Balance Valves on all Cylinders
  - Main Relief Valve
  - Anti Two-Block
  - Low Boom Angle
  - Low Cable on Winch Drum

# cobra 4400H

**PTO - HYDRAULIC CRANES**  
**16,000 FT. LBS.**

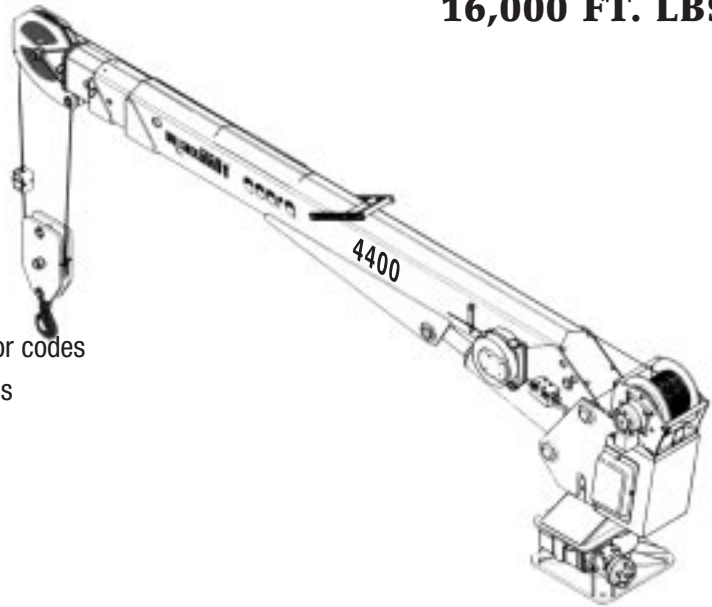

\* Cobra crane structures are designed for a normal working life of 12 to 15 years according to the DIN Standard 15018 classification H2-B3.

## TECHNICAL DATA

- Crane rating 16,000 ft. lbs.
- Horizontal reach 15'9"
- Elevation angle -5 to +80 degrees
- Slewing angle 400°
- Winch capacity, bare drum 2,290 lbs.
- Winch speed, single line 39 fpm
- Wire rope, non-rotating 82 ft of 5/16"
- Oil flow and pressure 2.65 gpm@2830 psi
- Crane weight 650 lbs.

## LIFTING CAPACITIES

FT.	LBS.	FT.	LBS.
4	4000	13	1230
5	3200	14	1140
6	2660	15'9"	990
7	2280		
8	2000		
9	1770		
10	1600		
11	1450		
12	1330		

## OPTIONS / ACCESSORIES

- Outriggers - manual or hydraulic
- Oil Reservoir

