



STANDARD FEATURES

- Engineered for 12 - 15 years of service*
- High strength hexagonal Swedish steel boom
- Boom Extension 1 Hydraulic / 1 Manual
- Hydraulic Planetary winch
- Worm gear rotation system
- HD fan cooled 12 V-DC power pack
- Load limiting device
- Single Proportional Control Valve
- Remote control - wireless and/or wired
- Emergency manual controls
- 2 part block
- Painted Cobra white with polyurethane enamel
- Cobra Diagnostics - displays safety, diagnostics and error codes
- 6 Standard Operator Safety and Crane Protection Devices
 - Overload Protection on all Functions
 - Counter Balance Valves on all Cylinders
 - Main Relief Valve
 - Anti Two-Block
 - Low Boom Angle
 - Low Cable on Winch Drum

cobra 4400E

12V-DC ELECTRO HYDRAULIC CRANES

16,000 FT. LBS.

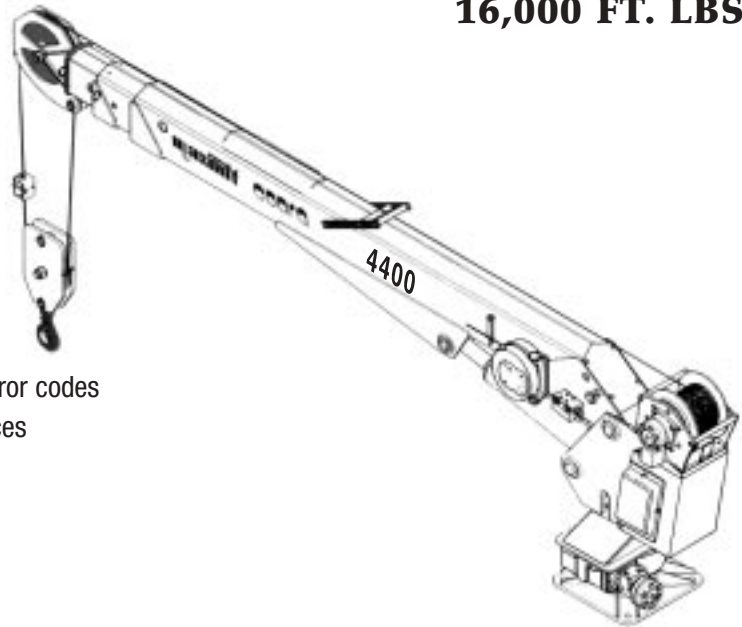

* Cobra crane structures are designed for a normal working life of 12 to 15 years according to the DIN Standard 15018 classification H2-B3.

TECHNICAL DATA

- Crane rating 16,000 ft. lbs.
- Horizontal reach 15'9"
- Elevation angle -5 to +80 degrees
- Slewing angle 400°
- Winch capacity, bare drum 2,290 lbs.
- Winch speed, single line 39 fpm
- Wire rope, non-rotating 82 ft of 5/16"
- Crane weight 715 lbs.

LIFTING CAPACITIES

FT.	LBS.	FT.	LBS.
4	4000	13	1230
5	3200	14	1140
6	2660	15'9"	990
7	2280		
8	2000		
9	1770		
10	1600		
11	1450		
12	1330		

OPTIONS / ACCESSORIES

- Outriggers - manual or hydraulic

