

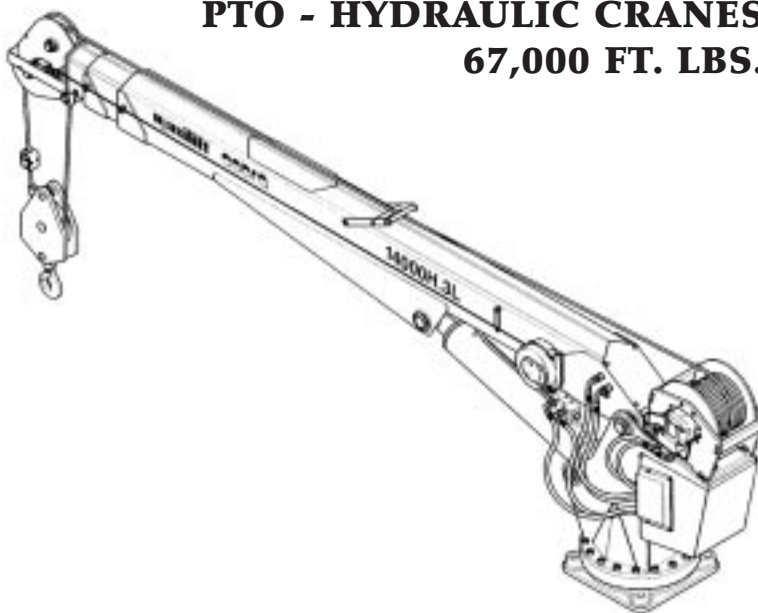

# cobra 14000H.3L

PTO - HYDRAULIC CRANES

67,000 FT. LBS.



## STANDARD FEATURES

- Engineered for 12 - 15 years of service\*
- High strength hexagonal Swedish steel boom
- Fully hydraulic boom extension/retraction
- Planetary hydraulic hoist winch
- Shear-ball bearing rotation system
- Planetary rotation drive
- Load limiting device
- Proportional multi-function control valve
- Remote control - wireless and/or wired
- Emergency manual controls
- 2 part block
- Anti-2 block safety switch
- Painted Cobra white with polyurethane enamel

\* Cobra crane structures are designed for a normal working life of 12 to 15 years according to the DIN Standard 15018 classification H2-B3.

## TECHNICAL DATA

- Crane rating 67,000 ft. lbs.
- Horizontal reach 27'6"
- Elevation angle -10 to +75 degrees
- Slewing angle continuous unlimited
- Winch capacity, bare drum 5,950 lbs.
- Winch speed, single line 40 fpm
- Wire rope, non-rotating 115 ft of 1/2"
- Oil flow and pressure 7 gpm@3,000 psi
- Crane weight 2,270 lbs.

## LIFTING CAPACITIES

FT.	LBS.	FT.	LBS.
5	11900	17	3900
6	11150	18	3700
7	9550	19	3500
8	8350	20	3350
9	7400	21	3150
10	6700	22	3000
11	6050	23	2900
12	5550	24	2750
13	5150	25	2650
4	4750	26	2500
15	4450	27'6"	2300
16	4150		

## OPTIONS / ACCESSORIES

- Outriggers - manual or hydraulic
- Oil reservoir

