

cobra 14000H.2L

PTO - HYDRAULIC CRANES

67,000 FT. LBS.

STANDARD FEATURES

- Engineered for 12 - 15 years of service*
- High strength hexagonal Swedish steel boom
- Fully hydraulic boom extension/retraction
- Planetary hydraulic hoist winch
- Shear-ball bearing rotation system
- Planetary rotation drive
- Load limiting device
- Proportional multi-function control valve
- Remote control - wireless and/or wired
- Emergency manual controls
- 2 part block
- Anti-2 block safety switch
- Painted Cobra white with polyurethane enamel

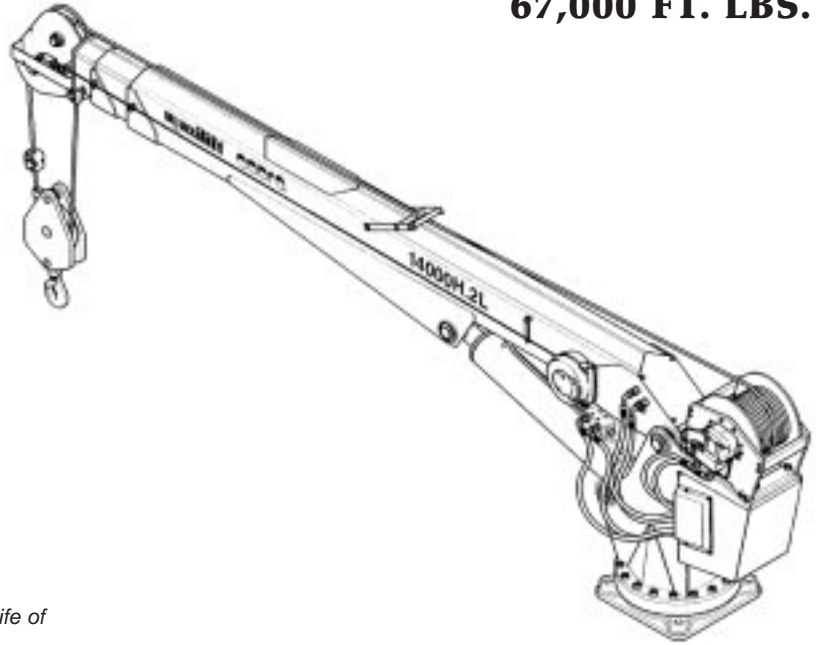

* Cobra crane structures are designed for a normal working life of 12 to 15 years according to the DIN Standard 15018 classification H2-B3.

TECHNICAL DATA

- Crane rating 67,000 ft. lbs.
- Horizontal reach 22'
- Elevation angle -10 to +75 degrees
- Slewing angle continuous unlimited
- Winch capacity, bare drum 5,950 lbs.
- Winch speed, single line 40 fpm
- Wire rope, non-rotating 115 ft of 1/2"
- Oil flow and pressure 7 gpm@3,000 psi
- Crane weight 2,100 lbs.

LIFTING CAPACITIES

FT.	LBS.	FT.	LBS.
5	11900	14	4750
6	11150	15	4450
7	9550	16	4150
8	8350	17	3900
9	7400	18	3700
10	6700	19	3500
11	6050	20	3350
12	5550	21	3150
13	5150	22'	2950

OPTIONS / ACCESSORIES

- Outriggers - manual or hydraulic
- Oil reservoir

