

cobra 11000H.3L

**PTO - HYDRAULIC CRANES
56,000 FT. LBS.**

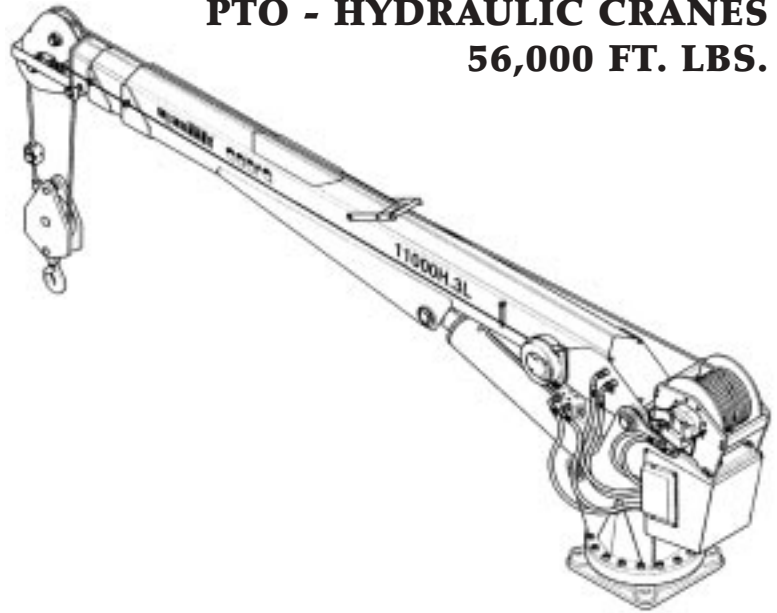

STANDARD FEATURES

- Engineered for 12 - 15 years of service*
- High strength hexagonal Swedish steel boom
- Fully hydraulic boom extension/retraction
- Planetary hydraulic hoist winch
- Shear-ball bearing rotation system
- Planetary rotation drive
- Load limiting device
- Proportional multi-function control valve
- Remote control - wireless and/or wired
- Emergency manual controls
- 2 part block
- Anti-2 block safety switch
- Painted Cobra white with polyurethane enamel

* Cobra crane structures are designed for a normal working life of 12 to 15 years according to the DIN Standard 15018 classification H2-B3.

TECHNICAL DATA

- Crane rating 56,000 ft. lbs.
- Horizontal reach 27'3"
- Elevation angle -10 to +75 degrees
- Slewing angle continuous unlimited
- Winch capacity, bare drum 5,800 lbs.
- Winch speed, single line 40 fpm
- Wire rope, non-rotating 115 ft of 7/16"
- Oil flow and pressure 7 gpm@2,850 psi
- Crane weight 2,000 lbs.

LIFTING CAPACITIES

FT.	LBS.	FT.	LBS.
5	10850	17	3250
6	9300	18	3000
7	8000	19	2900
8	7000	20	2800
9	6200	21	2650
10	5600	22	2500
11	5050	23	2400
12	4650	24	2300
13	4300	25	2200
14	4000	26	2150
15	3750	27'3"	1950
16	3500		

OPTIONS / ACCESSORIES

- Outriggers - manual or hydraulic
- Oil reservoir

