

cobra 11000H.2L

PTO - HYDRAULIC CRANES

56,000 FT. LBS.

STANDARD FEATURES

- Engineered for 12 - 15 years of service*
- High strength hexagonal Swedish steel boom
- Fully hydraulic boom extension/retraction
- Planetary hydraulic hoist winch
- Shear-ball bearing rotation system
- Planetary rotation drive
- Load limiting device
- Proportional multi-function control valve
- Remote control - wireless and/or wired
- Emergency manual controls
- 2 part block
- Anti-2 block safety switch
- Painted Cobra white with polyurethane enamel

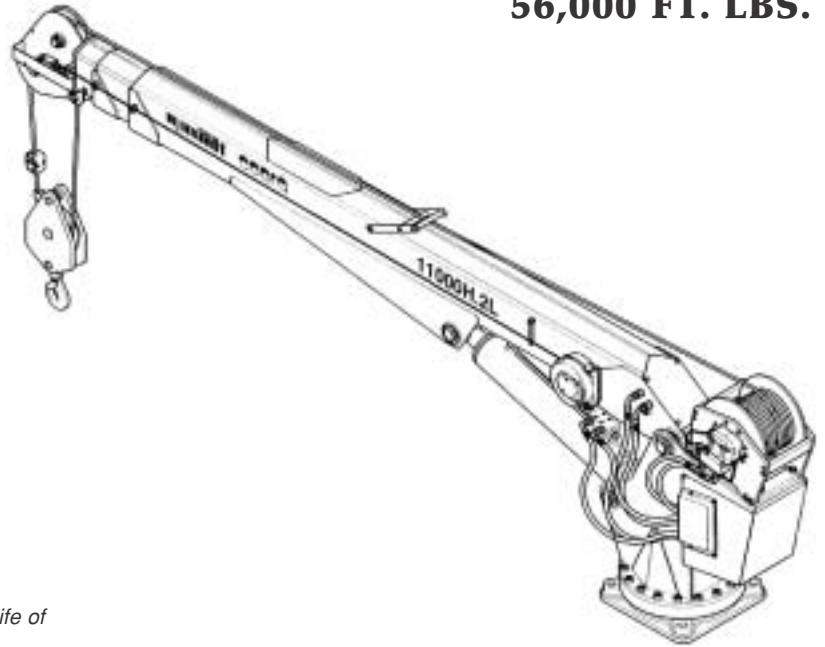

* Cobra crane structures are designed for a normal working life of 12 to 15 years according to the DIN Standard 15018 classification H2-B3.

TECHNICAL DATA

- Crane rating 56,000 ft. lbs.
- Horizontal reach 22 ft.
- Elevation angle -10 to +75 degrees
- Slewing angle continuous unlimited
- Winch capacity, bare drum 5,800 lbs.
- Winch speed, single line 40 fpm
- Wire rope, non-rotating 115 ft of 7/16"
- Oil flow and pressure 7 gpm@2,850 psi
- Crane weight 1,850 lbs.

LIFTING CAPACITIES

FT.	LBS.	FT.	LBS.
5	10850	14	4000
6	9300	15	3750
7	8000	16	3500
8	7000	17	3250
9	6200	18	3000
10	5600	19	2900
11	5050	20	2800
12	4650	21	2650
13	4300	22	2550

OPTIONS / ACCESSORIES

- Outriggers - manual or hydraulic
- Oil reservoir

